

Model101Touring

Product Features

Frying model

For middle field and far field

15mm plywood enclosure

Lightweight

Low weight Neodymium magnets throughout

Fibre glass molded horn

Neutrik speakON* NL4 connectors for reliable long life operation

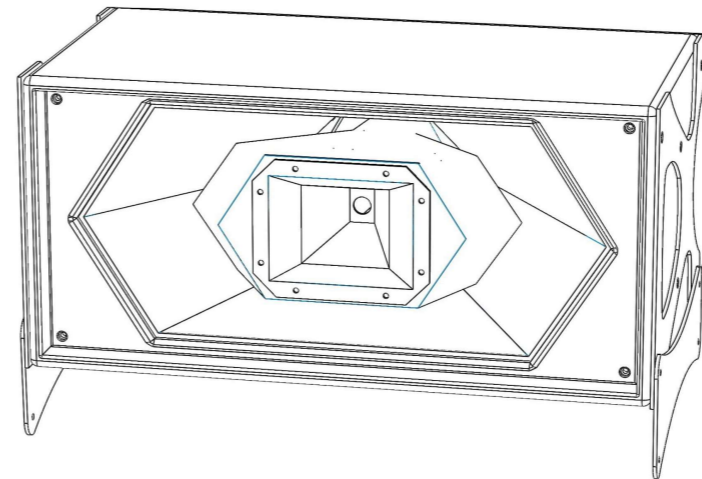
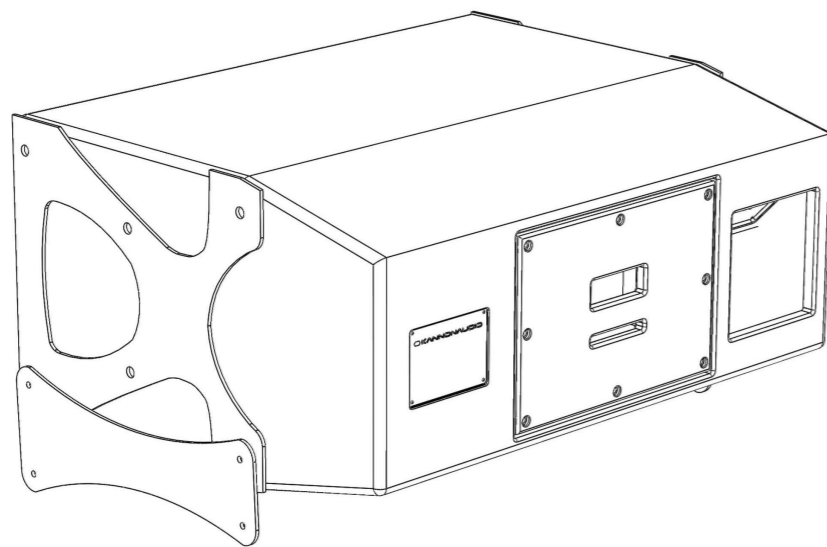

Driver	Frequency characteristic	Sensitivity 1W(2.8V) at 1m	Power (AES)	Nominal impedance
8"	290Hz-6kHz	dB	250w	16Ohm
1"	1kHz-20kHz	dB	80w	16Ohm
Frequency response	300Hz - 20kHz			
Weight	kg			
Nominal dispersion	75 Horizontal x 25 Vertical			
Connectors	2 x SpeakON* NL4			

Summary column

Model101 has a horizontal directivity of 75.

Since it has a wider directivity than the front road horns of other companies, it is possible to cover a wide area simply by stacking the main speakers vertically.

Model101 was designed for frying.

Use with Model102 and Model103.

Technical drawings

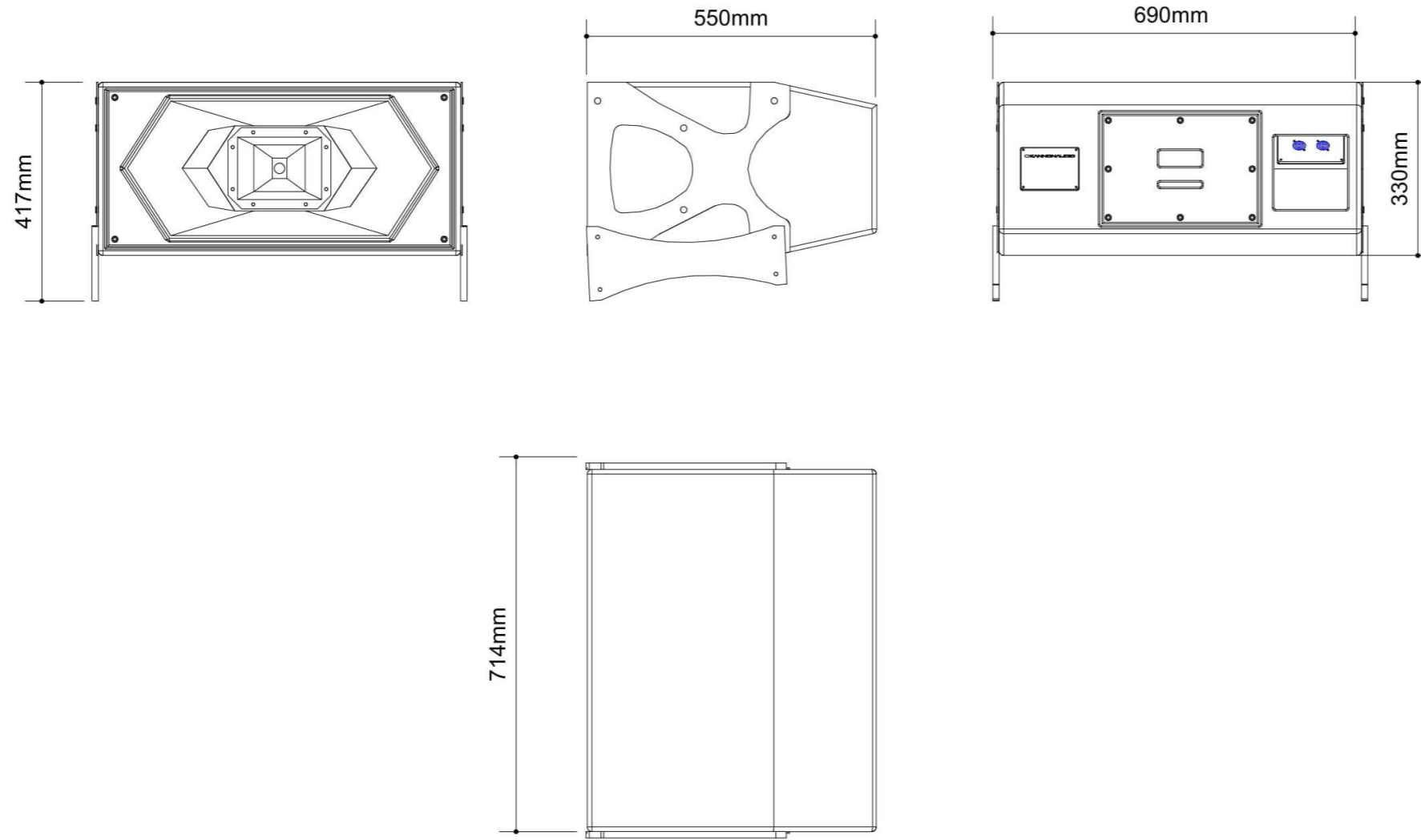

Model 101 Touring

Frying image

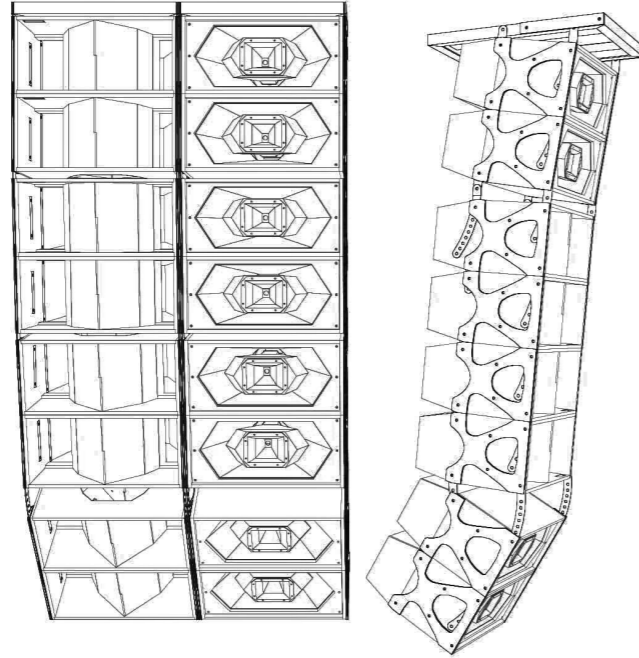

Frying system for touring

It is frying system for exclusive use of Model101 and Model102 of System100

Vertical is mechanism that allows a minimum adjustment 2.5.

This system can cover the venue thoroughly.

Download files

Accessories

Fright case

