

## Model102 Touring

### Product Features

Frying model

15mm plywood enclosure

Lightweight

Low weight Neodymium magnets throughout

Neutrik speakON\* NL4 connectors for reliable long life operation

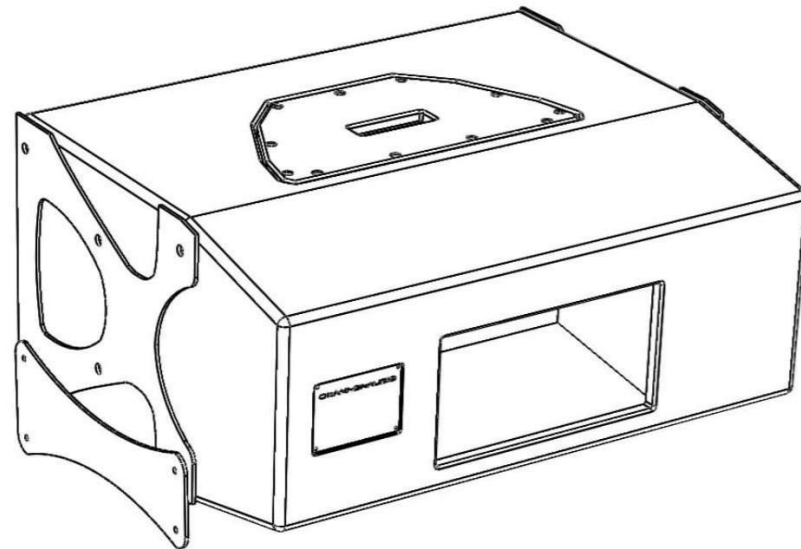
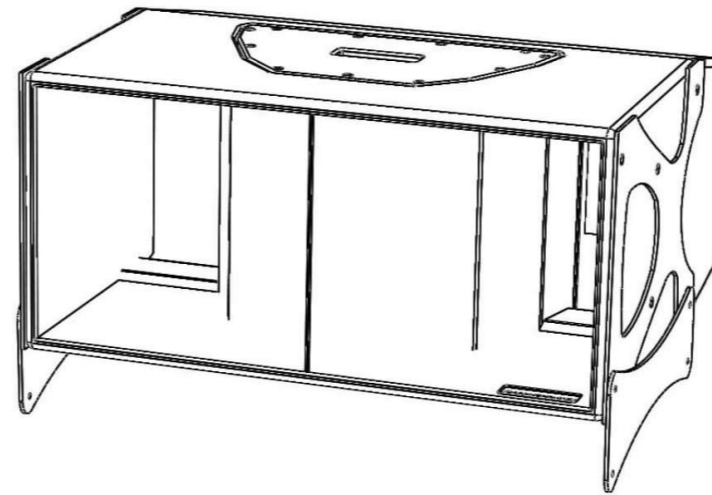

<b>Driver</b>	<b>FrequencyS characteristic</b>	<b>ensitivity 1W(2.8V) at 1m</b>	<b>Power (AES)</b>	<b>Nominal impedance</b>
10"	60Hz-7kHz	dB	250w	16Ohm
<b>Frequency response</b>	60Hz - 7kHz			
<b>Weight</b>	kg			
<b>Nominal dispersion</b>	90 Horizontal			
<b>Connectors</b>	2 x SpeakON* NL4			

### Summary column

Model102 has a horizontal directivity of 90.

Model102 was designed for frying.

Use with Model101 and Model103.

Technical drawings

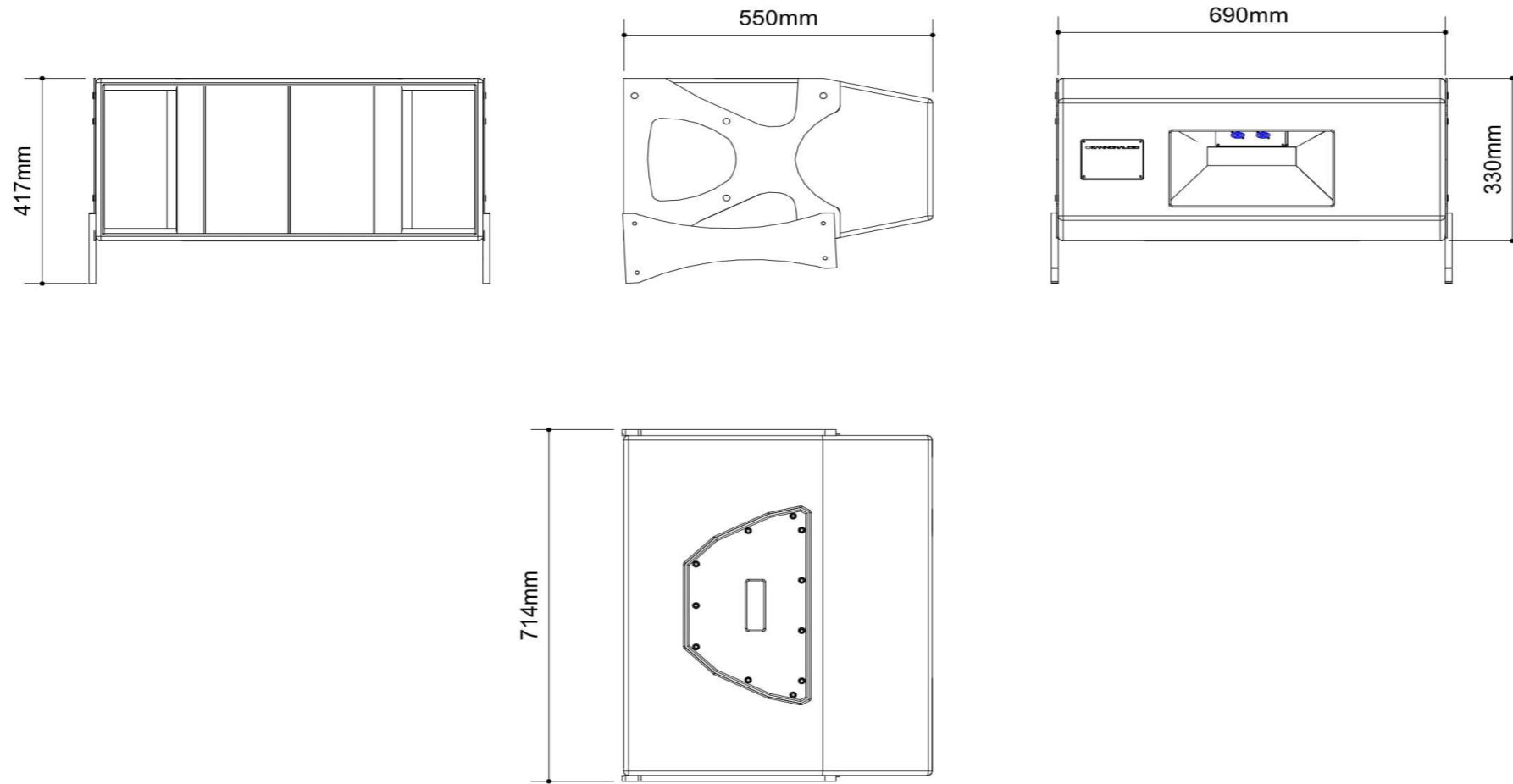

Model 102 Touring

Frying image

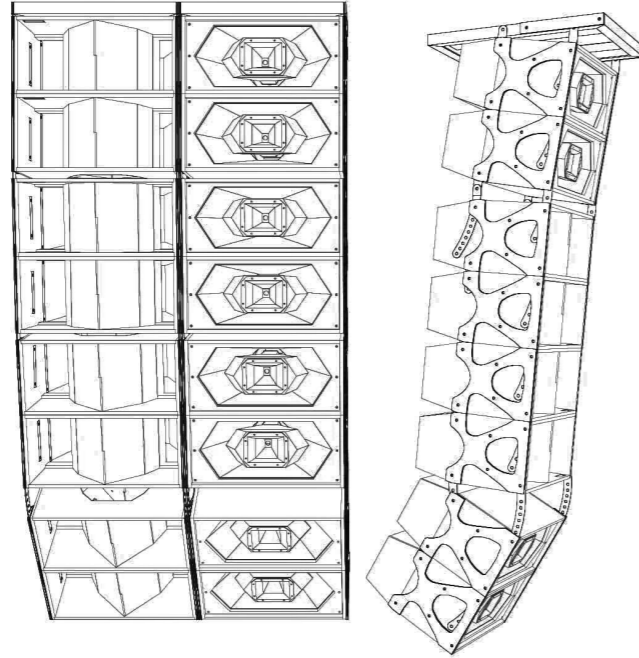

### Frying system for touring

It is frying system for exclusive use of Model101 and Model102 of System100

Vertical is mechanism that allows a minimum adjustment 2.5.

This system can cover the venue thoroughly.

Download files

### Accessories

Fright case

